



W.O. # 20180918 VERBAL
DATE: SEPTEMBER 18, 2018

Roosevelt Ridge

FROM	<i>Ted Bertele</i> HOA Director 303 618 8200 rooseveltridgebod@gmail.com	INVOICING	Karen Burback 12434 W 85 th Ave Arvada CO 80005 303-929-2229 KABPS@MSN.COM
TO	Steve Grapes Black Diamond Excavating 20 Venus Road Black Hawk CO 80422 (303) 601-4216 blackdiamondexcavation@gmail.com	JOB	Sagamore Trail Re-routing, culvert and drainage issues

Terms and Conditions – RR HOA

- Verbal work order, HOA provided Black Diamond authorization to proceed.

Terms & Conditions – Black Diamond Excavating

- Per BD standard T&Cs / Proposal

Item Number	DESCRIPTION	Unit	Rate	Qty	Total
	Re-route Sagamore Trail Entrance				
	Ditching				
	Install Culvert				
				Total	\$4,850

Sent: Monday, August 20, 2018 9:10 AM
To: Mike Wallace
Cc: Jeffrey Keicher
Subject: Re: Sagamore Trail

Fill requirements

- Restore to existing road edge slope and contour with a minimum rise of 12 inches above Sagamore trail realignment to control runoff
- Outside radius of driveway / fill section will be ditched to Roosevelt Ridge road
- Black Diamond will install the culvert and ditch RR Road



Just to make sure he does the new alignment correctly

- 20 ft width by 20 ft long minimum at intersection.
- 6% maximum gradient at intersection
- 3% crown to road ditches tapering at intersection
- 12-18 in ditches both sides ensuring runoff is controlled
- 30 ft minimum inside radius
- 45-60 deg turn

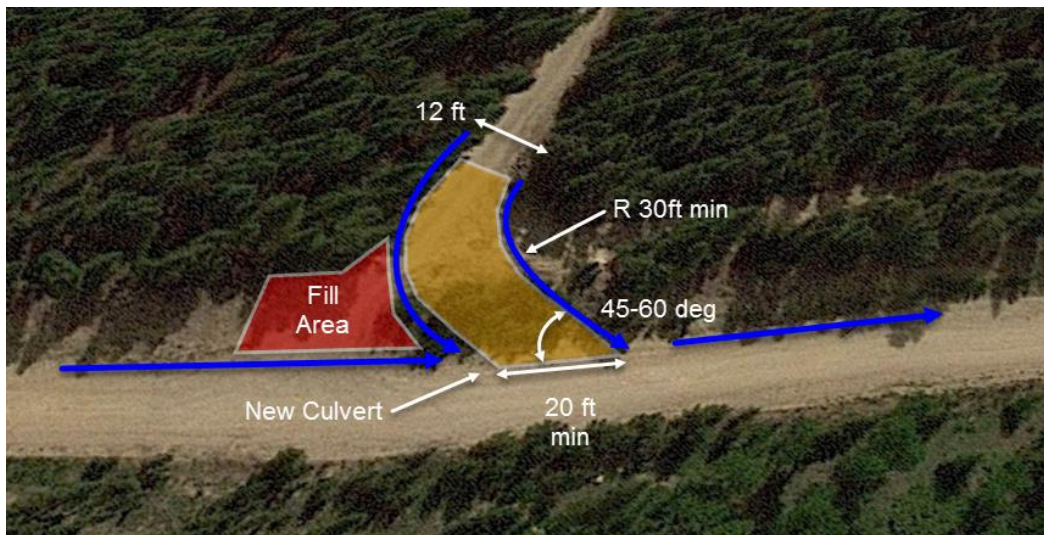
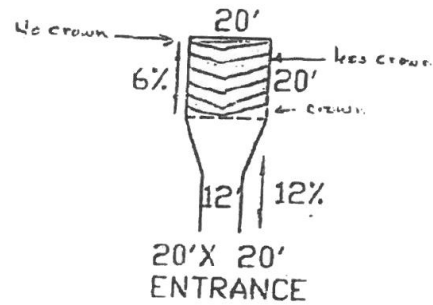

APPROVAL			
NAME	TITLE	DATE	SIGNATURE
TED BERTELE	DIRECTOR, RR HOA	9/18/2018	THEODORE BERTELE

THANK YOU FOR YOUR BUSINESS!